

■ Profile profiles

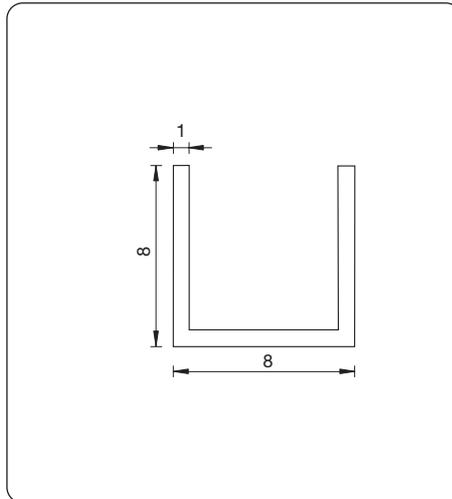

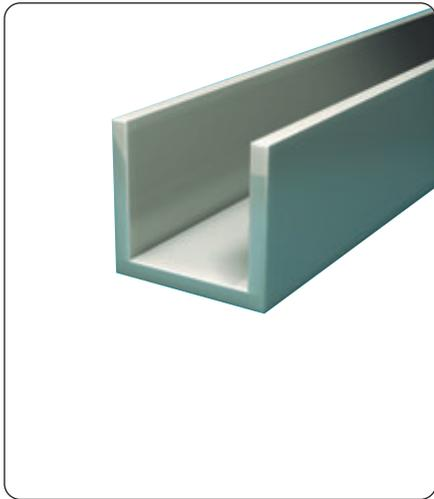

Einzelteile | single components



Art. Nr. item no.: 5000	
U-Profil u-profile	8 x 8 x 5000 x 1 mm
Plattendicke plate thickness:	≤ 6 mm
Material:	Aluminium

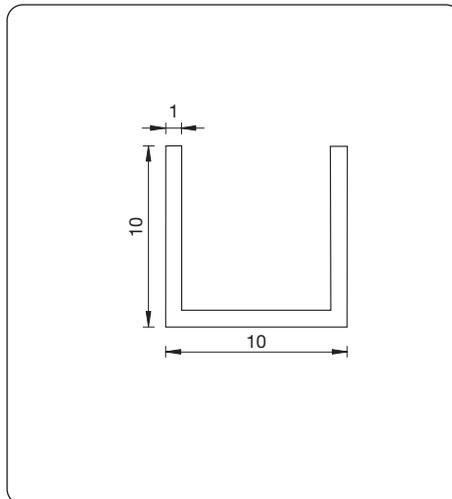

Art. Nr. item no.: 5010	
U-Profil u-profile	10 x 10 x 5000 x 1 mm
Plattendicke plate thickness:	≤ 8 mm
Material:	Aluminium

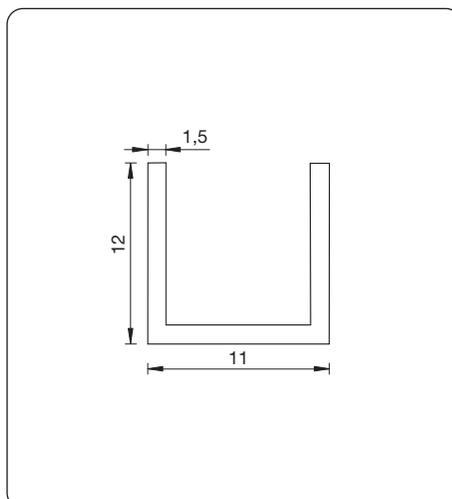

Art. Nr. item no.: 5012	
U-Profil u-profile	12 x 11 x 5000 x 1,5 mm
Plattendicke plate thickness:	≤ 8 mm
Material:	Aluminium



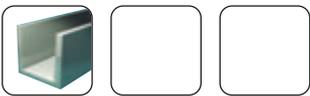

■ Einzelteile | single components

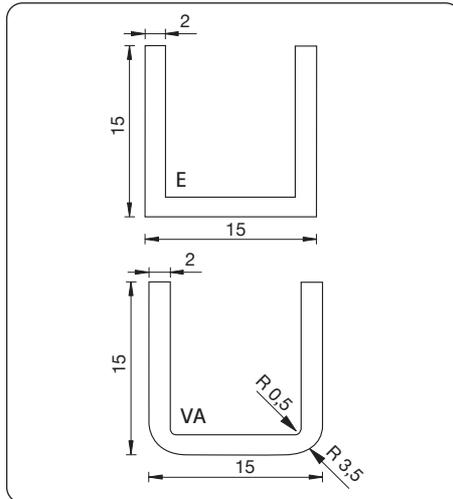
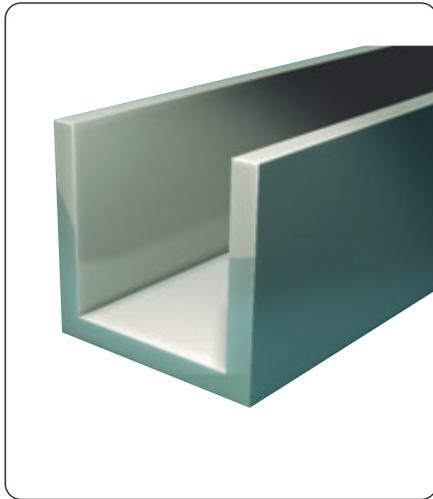

Art. Nr. | item no.: 5015

U-Profil | u-profile 15 x 15 x 5000 x 2 mm

Plattendicke | plate thickness: ≤ 11 mm

Material: E = Aluminium, VA = A2



E6EV1 E6EV5 E1/22 E3/50 E0/14



VA1 VA2

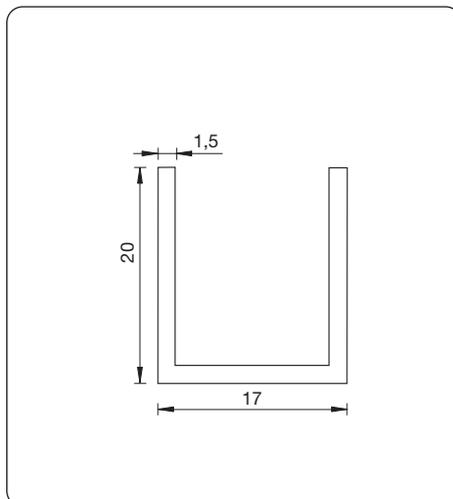

Art. Nr. | item no.: 5017

U-Profil | u-profile 20 x 17 x 5000 x 1,5 mm

Plattendicke | plate thickness: ≤ 14 mm

Material: Aluminium



E6EV1 E6EV5 E1/22 E3/50 E0/14

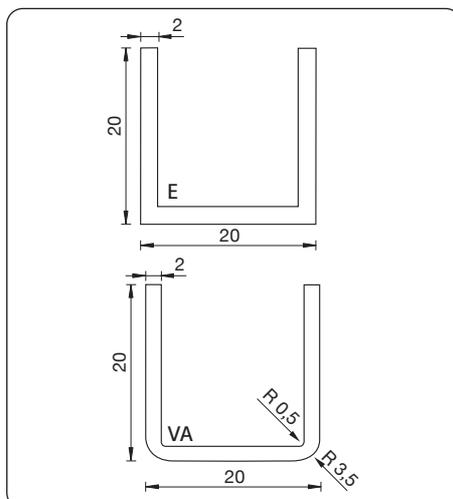

Art. Nr. | item no.: 5020

U-Profil | u-profile 20 x 20 x 5000 x 2 mm

Plattendicke | plate thickness: ≤ 16 mm

Material: E = Aluminium, VA = A2



E6EV1 E1/22 E3/50 E0/14



VA1 VA2

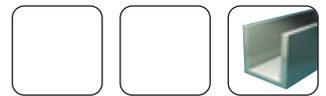

Einzelteile | single components

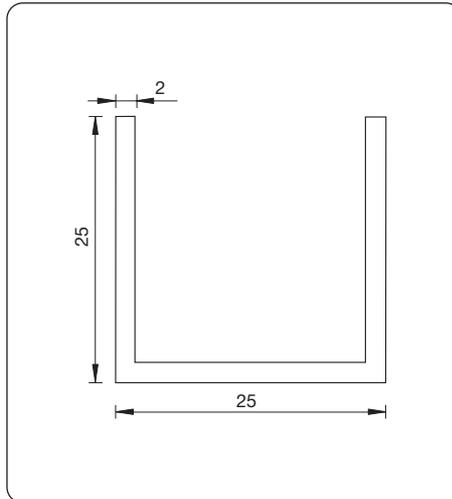
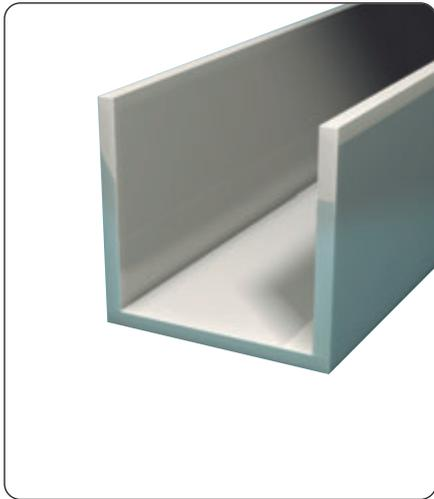

Art. Nr. item no.: 5025	
U-Profil u-profile	25 x 25 x 5000 x 2 mm
Plattendicke plate thickness:	≤ 21 mm
Material:	Aluminium

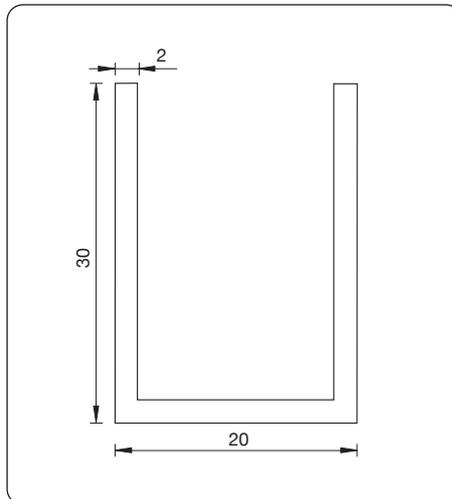
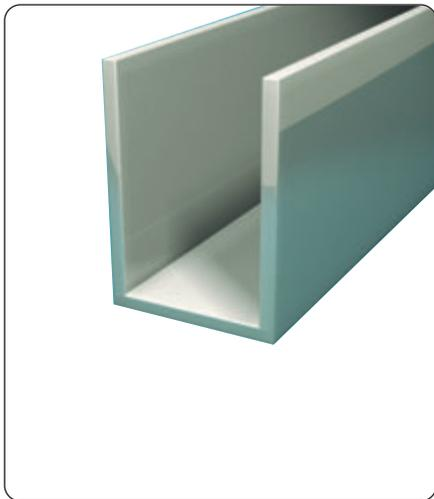

Art. Nr. item no.: 5030	
U-Profil u-profile	30 x 20 x 5000 x 2 mm
Plattendicke plate thickness:	≤ 16 mm
Material:	Aluminium

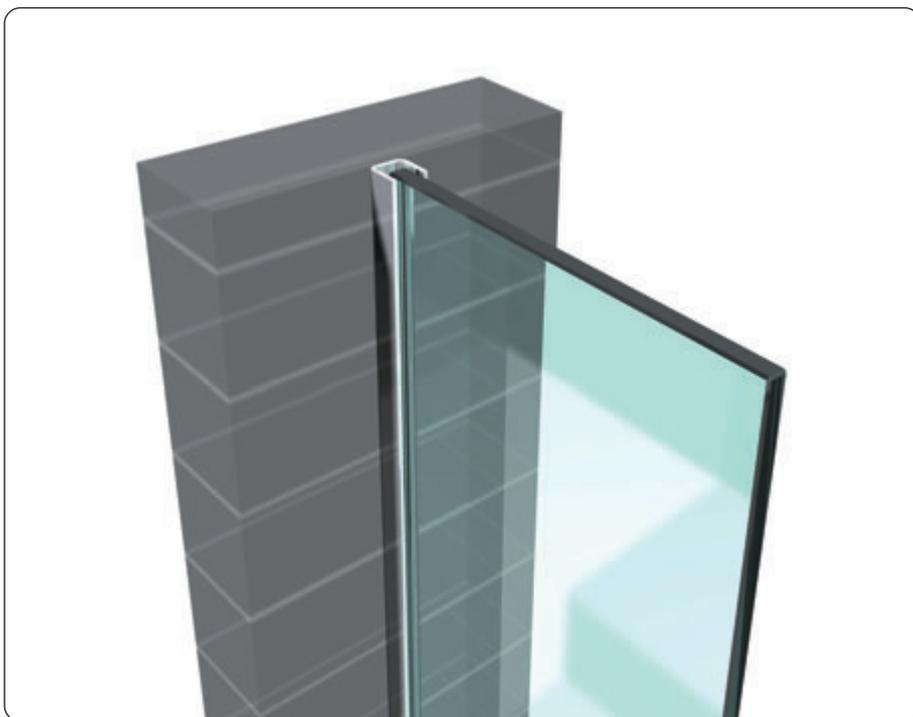

U-Profil | u-profile



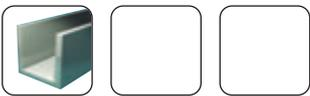

■ Einzelteile | single components

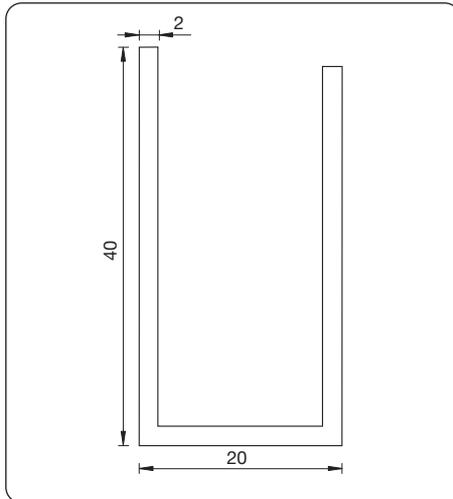
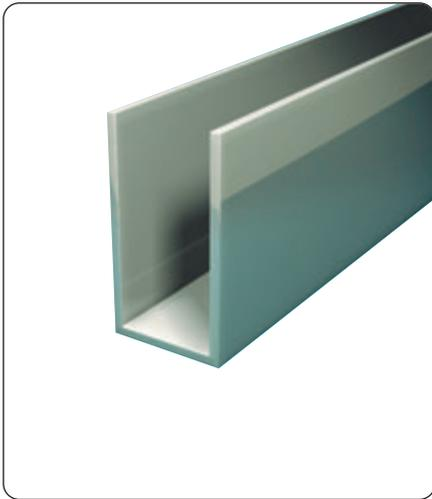

Art. Nr. | item no.: 5040

U-Profil | u-profile 40 x 20 x 5000 x 2 mm

Plattendicke | plate thickness: ≤ 16 mm

Material: Aluminium



E6EV1



E1/22



E0/14

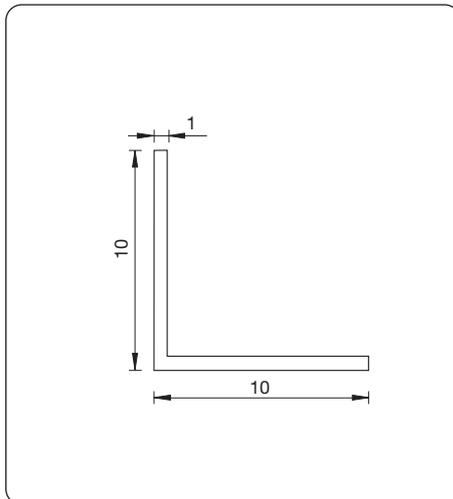
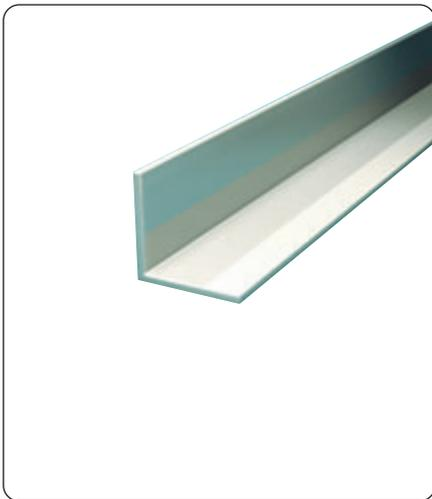

Art. Nr. | item no.: 5110

Winkelprofil 10 x 10 x 5000 x 1 mm
angle profile

Plattendicke | plate thickness: -

Material: Aluminium



E6EV1



E1/22

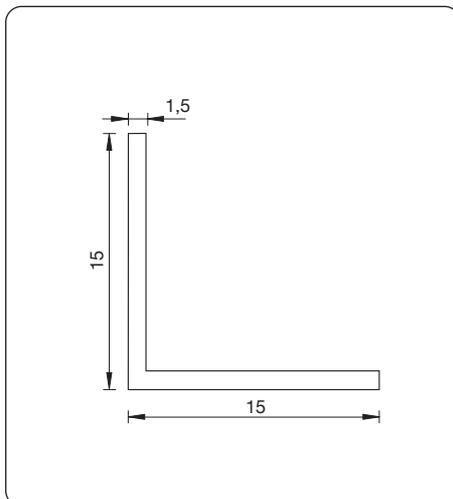
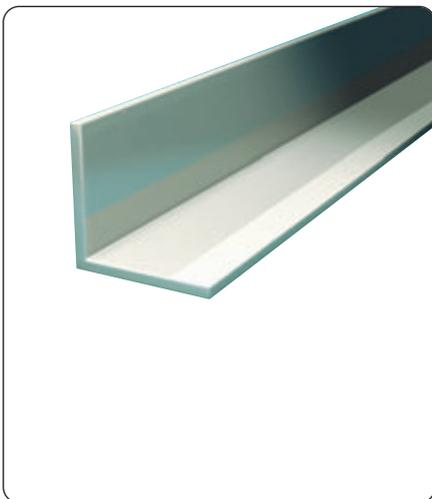

Art. Nr. | item no.: 5115

Winkelprofil 15 x 15 x 5000 x 1,5 mm
angle profile

Plattendicke | plate thickness: -

Material: Aluminium



E6EV1



E1/22

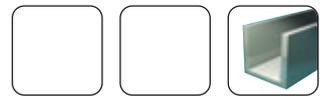

Einzelteile | single components

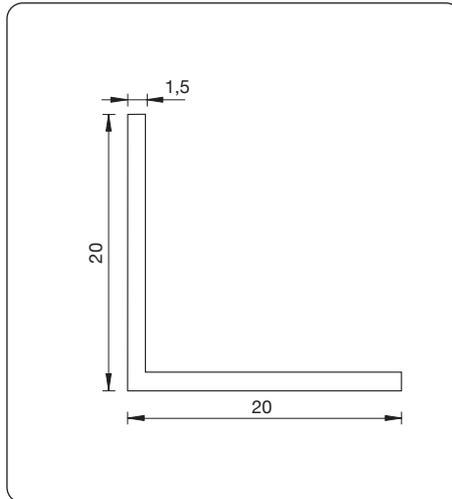

Art. Nr. | item no.: 5120

Winkelprofil 20 x 20 x 5000 x 1,5 mm
angle profile

Plattendicke | plate thickness: -

Material: Aluminium

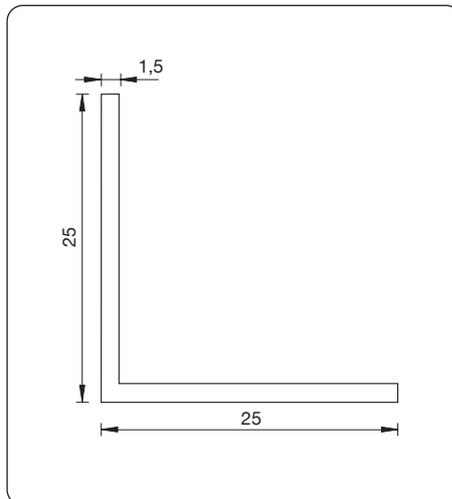
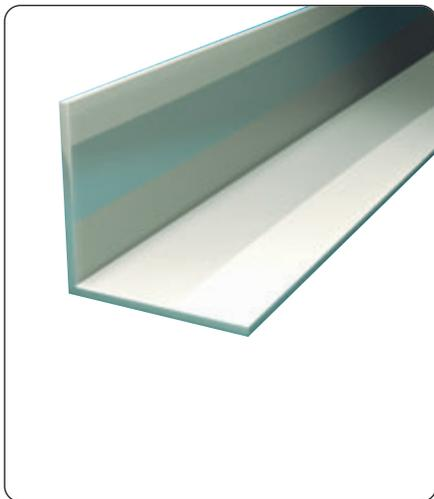

Art. Nr. | item no.: 5125

Winkelprofil 25 x 25 x 5000 x 1,5 mm
angle profile

Plattendicke | plate thickness: -

Material: Aluminium

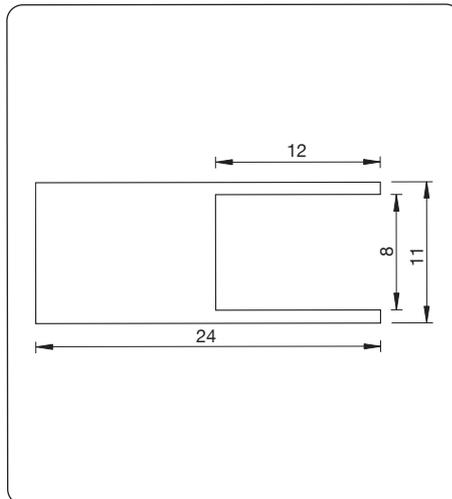

Art. Nr. | item no.: 5200

End-Profil 24 x 11 x 5000 x 1,5 mm
end profile

Plattendicke | plate thickness: ≤ 8 mm

Material: Aluminium





■ Einzelteile | single components

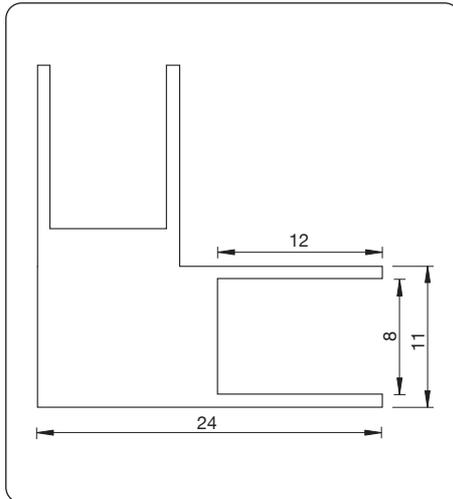

Art. Nr. | item no.: 5201

Eck-Profil 24 x 11 x 5000 x 1,5 mm
corner profile

Plattendicke | plate thickness: ≤ 8 mm

Material: Aluminium



E6EV1

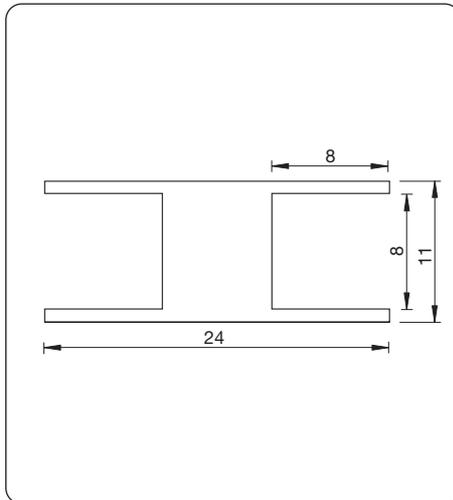
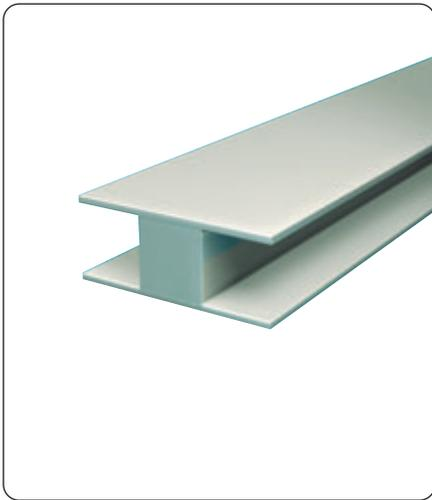

Art. Nr. | item no.: 5202

Mittelprofil 24 x 11 x 5000 x 1,5 mm
middle profile

Plattendicke | plate thickness: ≤ 8 mm

Material: Aluminium



E6EV1



Eckprofile | corner profiles

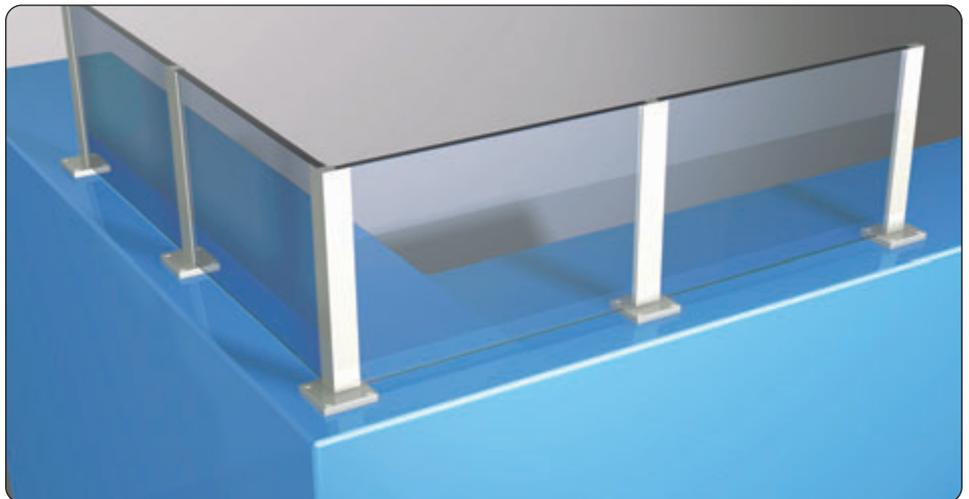

Trennwandstütze, Anwendung für nächste Seite
partition wall support, application for next page

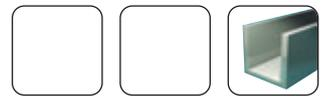

■ Einzelteile | single components

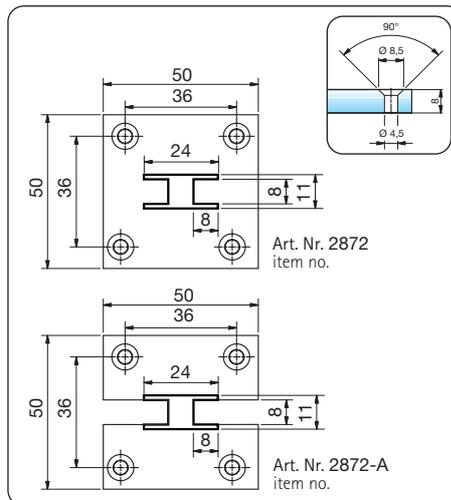

Art. Nr. | item no.: 2872 | 2872-A

Trennwand-Mittelstütze
Höhe 150 - 1000 mm, jeweils um 50 mm steigend
partition wall middle support , height 150 - 1000
mm, with increments of 50 mm

Plattendicke | plate thickness: ≤ 8 mm

Material: Aluminium

2872 ohne Ausklindung | without notch

2872-A mit Ausklindung | with notch



E6EV1

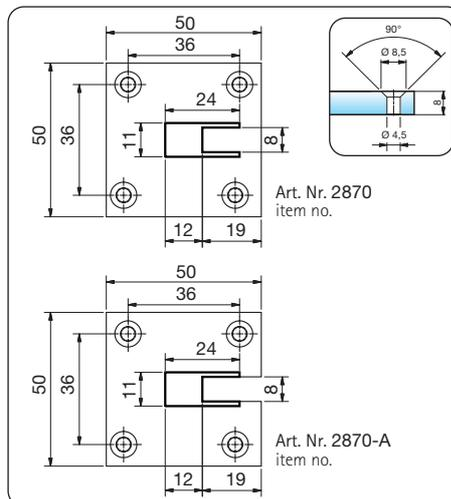

Art. Nr. | item no.: 2870 | 2870-A

Trennwand-Endstütze
Höhe 150 - 1000 mm, jeweils um 50 mm steigend
partition wall end support , height 150 - 1000
mm, with increments of 50 mm

Plattendicke | plate thickness: ≤ 8 mm

Material: Aluminium

2870 ohne Ausklindung | without notch

2870-A mit Ausklindung | with notch



E6EV1

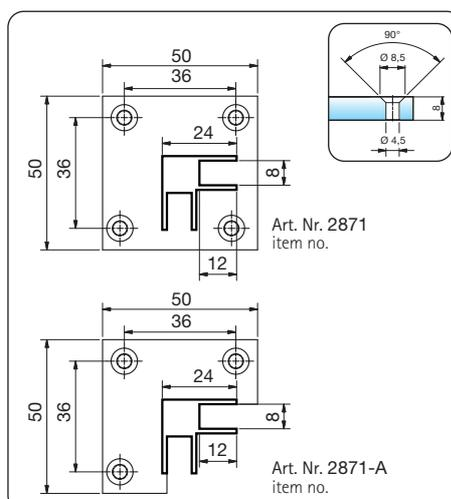

Art. Nr. | item no.: 2871 | 2871-A

Trennwand-Eckstütze
Höhe 150 - 1000 mm, jeweils um 50 mm steigend
partition wall corner support , height 150 - 1000
mm, with increments of 50 mm

Plattendicke | plate thickness: ≤ 8 mm

Material: Aluminium

2871 ohne Ausklindung | without notch

2871-A mit Ausklindung | with notch



E6EV1



■ Einzelteile | single components

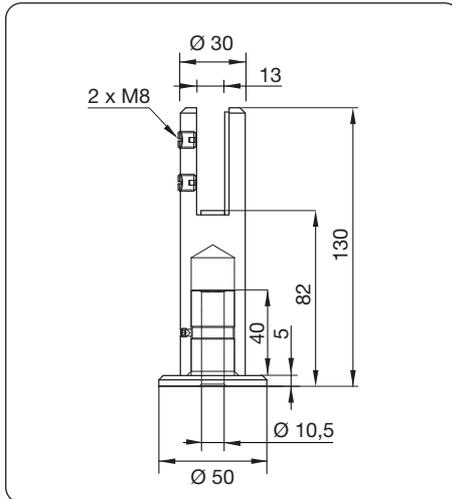

Art. Nr. | item no.: 31322VA

Bodenhalter für vertikale Glasbefestigung
floor mount for vertical glazing

Plattendicke | plate thickness: ≤ 12 mm

Material: A2 (1.4301)

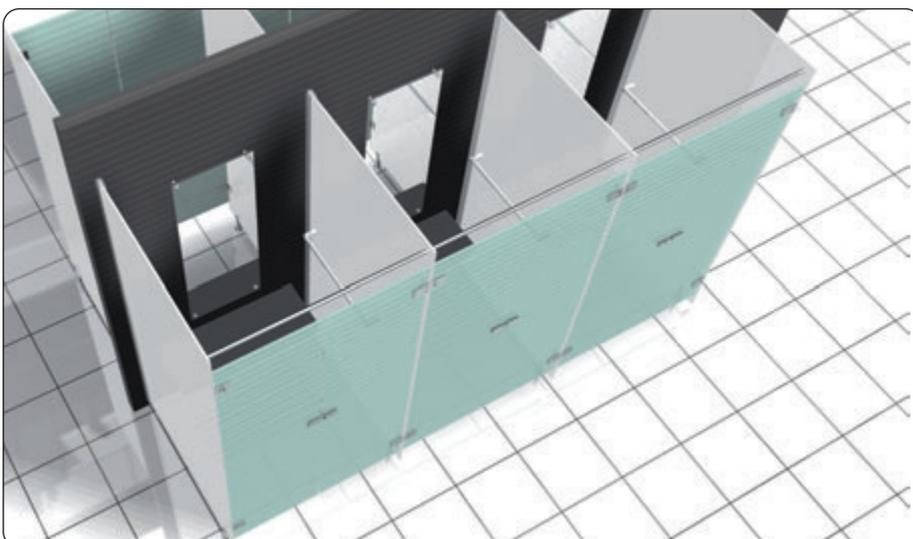



■ Einzelteile | single components

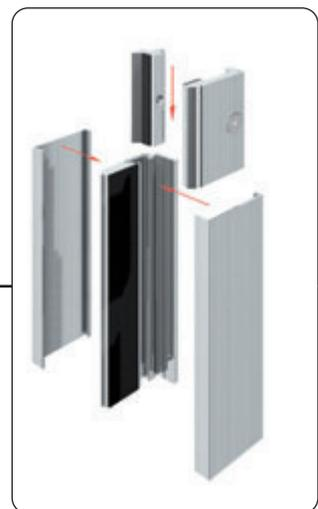



Einzelteile | single components

NEW

Anwendung für vertikale Anbringung | application for vertical assembly

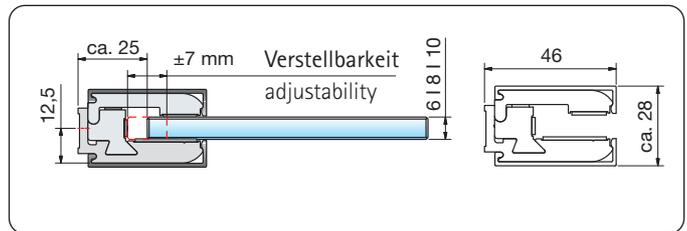

Zubehör | accessoires
Zwischenlagen für 8884 |
intermediate layers for 8884

Art. Nr. | item no: 8885HZ

8885 Zwischenlage zum Ausgleich von Unebenheiten in der Wand:
Durch Kombination und/oder Verdopplung können Unebenheiten ab 2 mm in 1-mm-Schritten ausgeglichen werden. 5 pro Stärke enthalten.

To remove any unevenness in the wall. Unevenness can be removed from 2 mm in 1-mm stages through combining and/or doubling. 5 pcs. per thickness.

NEW

Zubehör | accessoires
Sicherungsstift | locking pin

Art. Nr. | item no: 8886

Für Anwendung Deckenabhängung pro Klemmbacke 1 Sicherungsstift | for each clamping jaw for ceiling mounting

Glasbearbeitung mit Sicherungsstift | glass processing with locking pin

Glasbearbeitung mit Entlastungsschnitt
glass processing with relief cut

einzelne Klemmbacke
single bracket

Anwendung für Oberlicht | application for overhead light

Versiegelung
sealing

8886VA

18 6 Ø10 38

Bitte Bohrung vorsehen
bore to be provided

Bohrung werkseitig vorhanden
factory-made drilling

Art. Nr. | item no.: 8884__-5000

Klemmprofil | clamping profile

Einzelne Klemmbacken auf gesamter Länge positionierbar
single clamping jaws movable on complete profile length

8884__-5000

6 | 8 | 10 mm





■ Zubehör Klemmprofil | accessories clamping profile

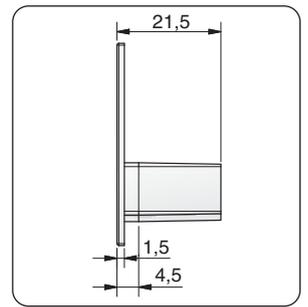
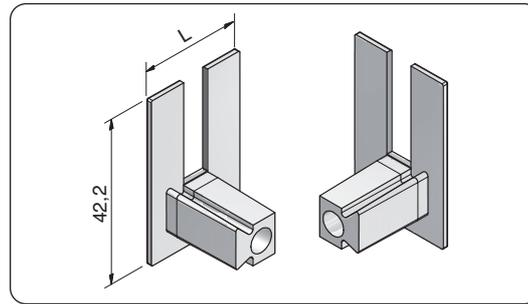
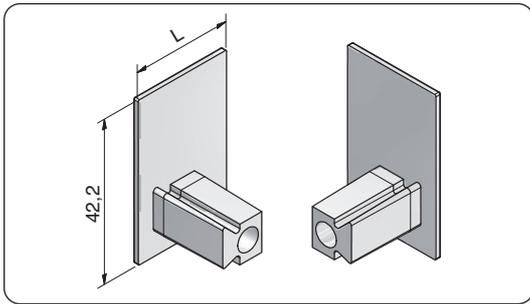

Art. Nr.: | item no.: 8884-8KU_

Endkappen für Klemmprofil für 8884 | end cap for clamping profile 8884

Material: Kunststoff | plastic

8884-8KU_L-6 geschlossen links | closed left

8884-8KU_L-8 geschlossen links | closed left

8884-8KU_L-10 geschlossen links | closed left

8884-8KU_R-6 geschlossen rechts | closed right

8884-8KU_R-8 geschlossen rechts | closed rechts

8884-8KU_R-10 geschlossen rechts | closed rechts

Art. Nr.: | item no.: 8884-9KU_

Endkappen für Klemmprofil für 8884 | end cap for clamping profile 8884

Material: Kunststoff | plastic

8884-9KU_L-6 ausgeklinkt links | notched links

8884-9KU_L-8 ausgeklinkt links | notched links

8884-9KU_L-10 ausgeklinkt links | notched links

8884-8KU_R-6 ausgeklinkt rechts | notched rechts

8884-8KU_R-8 ausgeklinkt rechts | notched rechts

8884-8KU_R-10 ausgeklinkt rechts | notched rechts

L = 26 mm - 6 mm Glas | glass

L = 28 mm - 8 mm Glas | glass

L = 30 mm - 10 mm Glas | glass

Beispiel Farbwahl:
example color options:
8884-8KU_L-6 =
8884-8KU6L-6

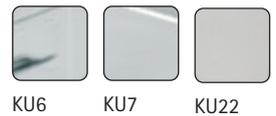

■ Anwendungen | applications

