



# Pistekiinnityshelat

fix point fixtures by P+S



**Tekninen tieto**  
technical information

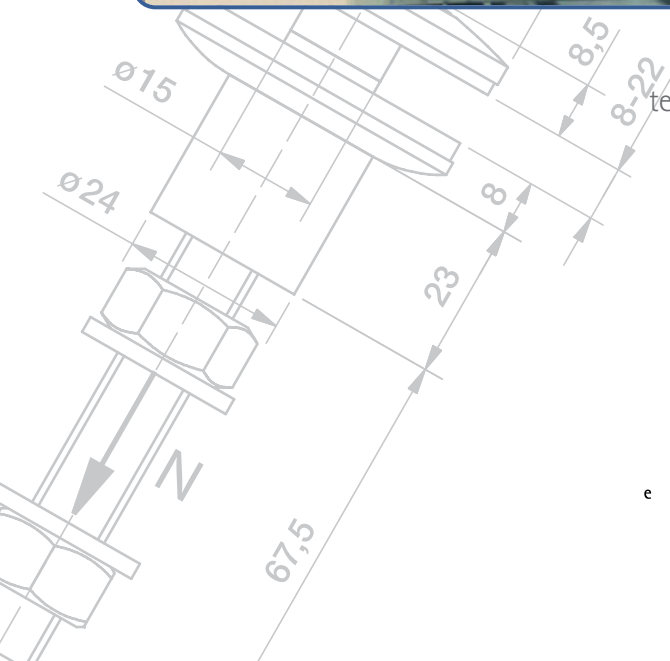



## Julkisivuhelat | facade point fixings

Tekninen laatu ja edut lasiasennuksen aikana ovat pysyneet etualalla kehityksessä. Pistekiinnike valikoimaa on laajennettu lisäämällä tyyppejä ja halkaisijoita eri kuormituksille ja lasipaksuuksille. Modulaarinen järjestelmä mahdollistaa optimaalisen ja joustavan rakenteen, koska lasikerroksen ja alusrakenteen välinen etäisyys pysyy aina samana riippumatta käytetystä kiinnityskohdasta.

Technical sophistication and advantages during assembly of glazing have been standing in the foreground during development. The point fixtures are characterized by an enlarged range of types and diameters, for different load capacities and glass thickness. The modular system enables optimal and flexible design, since the distance between glass layer and substructure remains always the same, regardless of the used point fixture.



# Julkisivuhelat | facade point fixings

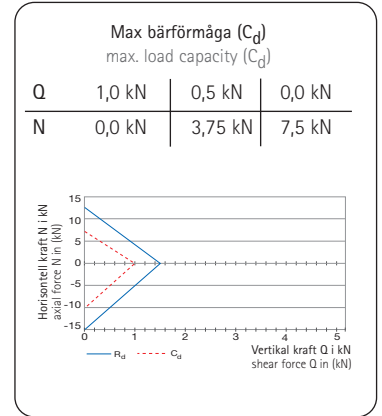
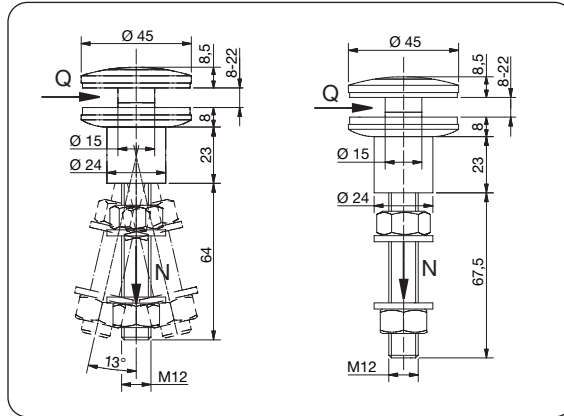

Art.nr article no.	Material material	Benämning article name	Diameter plate diameter	Borrhål i glas glass bore	Gängstång thread	Godkännande approval
751245VAM12 750245VAM12	A4	ledbar, utanpåliggande   articulated, raised head fast, utanpåliggande   fixed, raised head	Ø 45 mm	Ø 18 mm	M12	AbZ Z-70.2-135

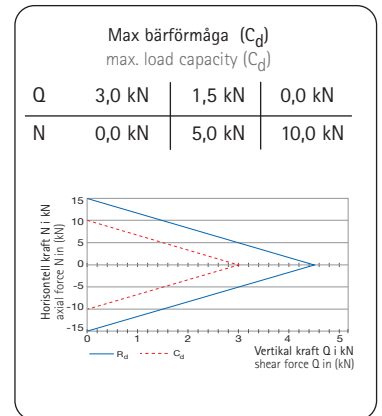
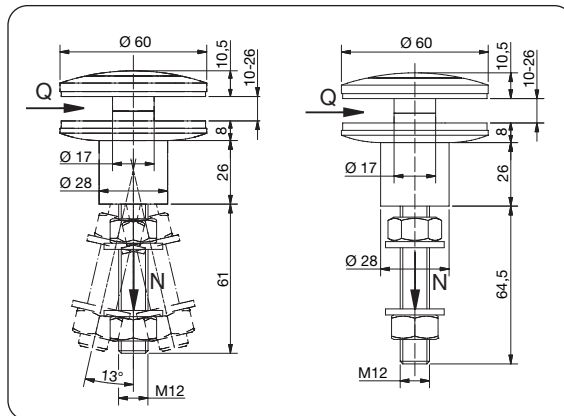

Art.nr article no.	Material material	Benämning article name	Diameter plate diameter	Borrhål i glas glass bore	Gängstång thread	Godkännande approval
751260VAM12 750260VAM12	A4	ledbar, utanpåliggande   articulated, raised head fast, utanpåliggande   fixed, raised head	Ø 60 mm	Ø 22 mm	M12	AbZ Z-70.2-135

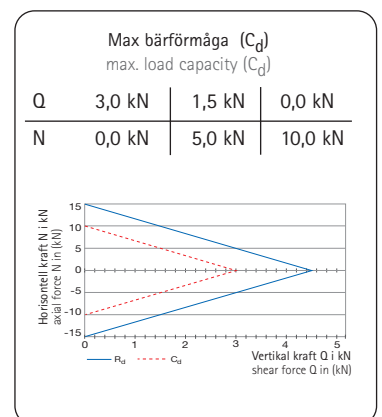
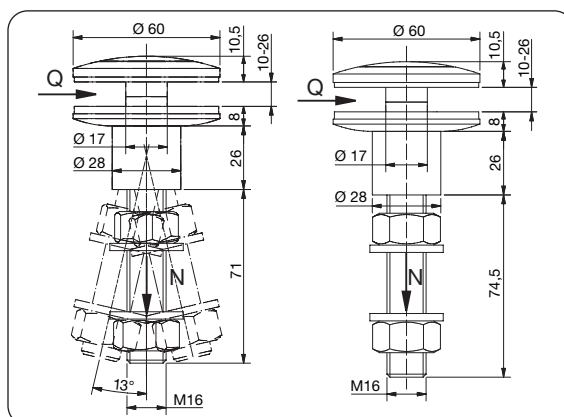

Art.nr article no.	Material material	Benämning article name	Diameter plate diameter	Borrhål i glas glass bore	Gängstång thread	Godkännande approval
751260VAM16 750260VAM16	A4	ledbar, utanpåliggande   articulated, raised head fast, utanpåliggande   fixed, raised head	Ø 60 mm	Ø 22 mm	M16	AbZ Z-70.2-135



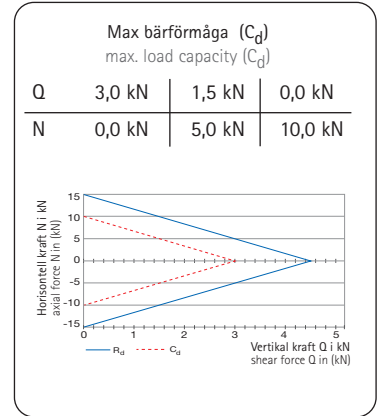
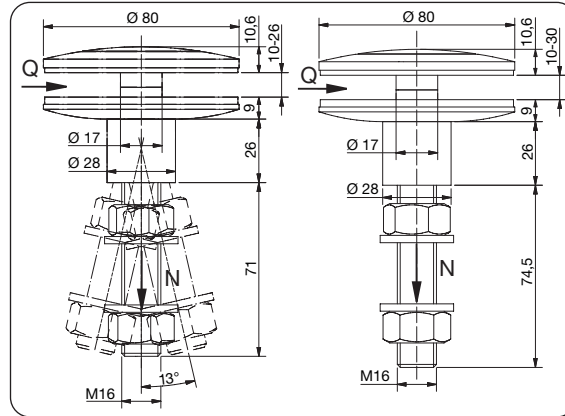

Art.nr article no.	Material material	Benämning article name	Diameter plate diameter	Borrhål i glas glass bore	Gängstång thread	Godkännande approval
751280VAM16 750280VAM16	A4	ledbar, utanpåliggande   articulated, raised head fast, utanpåliggande   fixed, raised head	Ø 80 mm	Ø 22 mm	M16	AbZ Z-70.2-135

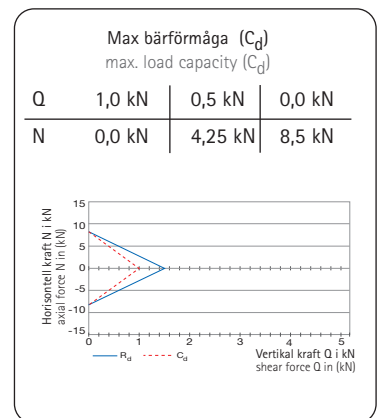
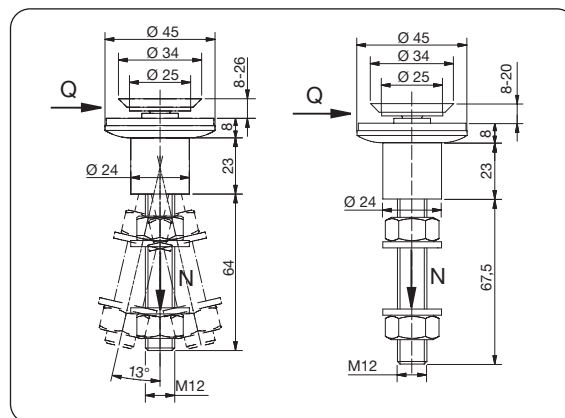
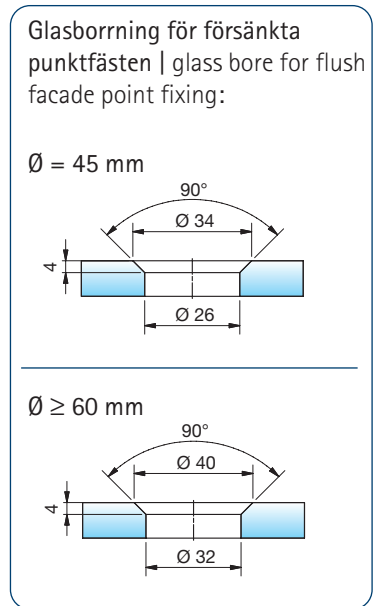

Art.nr article no.	Material material	Benämning article name	Diameter plate diameter	Gängstång thread
751345VAM12 750345VAM12	A4	ledbar, försänkt   articulated, flush fast, försänkt   fixed, flush	Ø 45 mm	M12





# Julkisivuhelat | facade point fixings

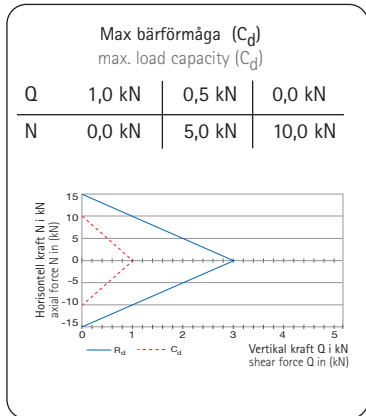
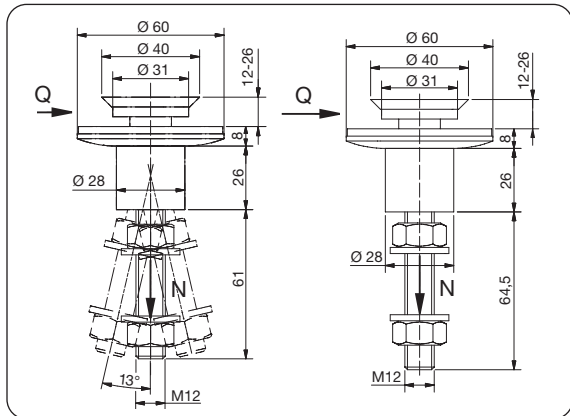

Art.nr article no.	Material material	Benämning article name	Diameter plate diameter	Gängstång thread
751360VAM12 750360VAM12	A4	ledbar, försänkt   articulated, flush fast, försänkt   fixed, flush	Ø 60 mm	M12

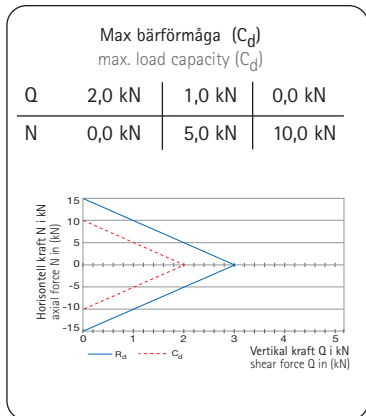
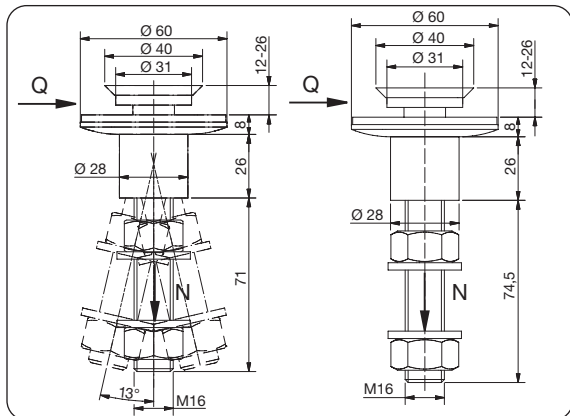

Art.nr article no.	Material material	Benämning article name	Diameter plate diameter	Gängstång thread
751360VAM16 750360VAM16	A4	ledbar, försänkt   articulated, flush fast, försänkt   fixed, flush	Ø 60 mm	M16

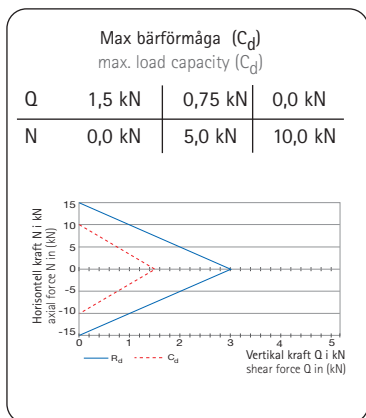
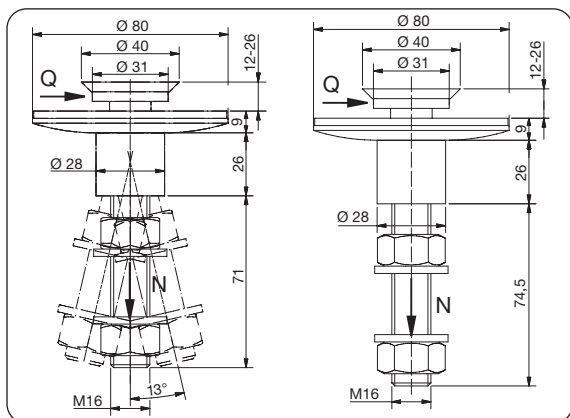

Art.nr article no.	Material material	Benämning article name	Diameter plate diameter	Gängstång thread
751380VAM16 750380VAM16	A4	ledbar, försänkt   articulated, flush fast, försänkt   fixed, flush	Ø 80 mm	M16

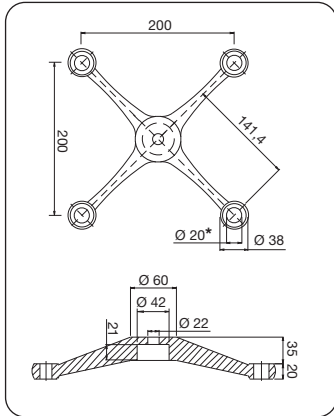

Art.nr article no.	Material material	Benämning article name
-----------------------	----------------------	---------------------------

7491VA	A4	Spider 4-arm   spider 4-arm
--------	----	-----------------------------

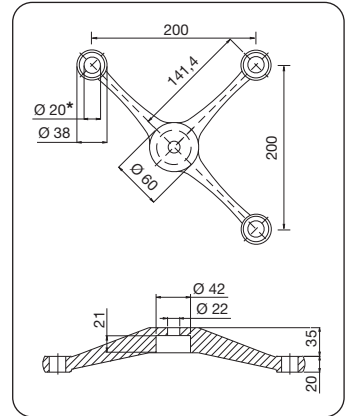

Art.nr article no.	Material material	Benämning article name
-----------------------	----------------------	---------------------------

7481VA	A4	Spider 3-arm   spider 3-arm
--------	----	-----------------------------

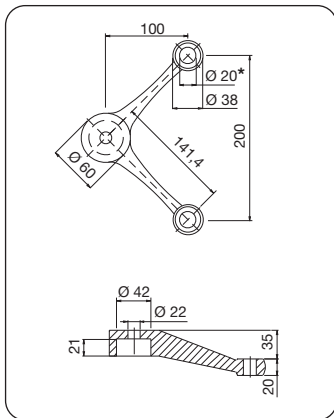

Art.nr article no.	Material material	Benämning article name
-----------------------	----------------------	---------------------------

7476VA	A4	Spider 2-arm, 90°   spider 2-arm, 90°
--------	----	---------------------------------------

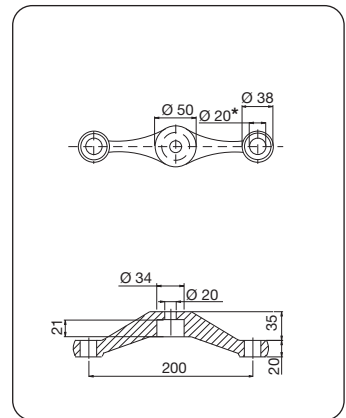

Art.nr article no.	Material material	Benämning article name
-----------------------	----------------------	---------------------------

7471VA	A4	Spider 2-arm, 180°   spider 2-arm, 180°
--------	----	---

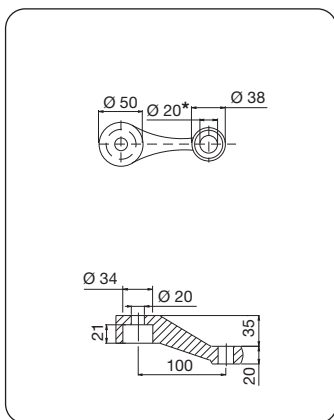

Art.nr article no.	Material material	Benämning article name
-----------------------	----------------------	---------------------------

7476VA	A4	Spider 1-arm, kort   spider 1-arm, short
--------	----	--

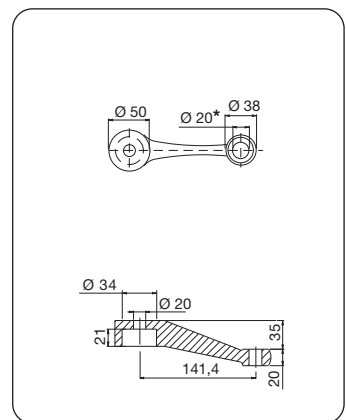

Art.nr article no.	Material material	Benämning article name
-----------------------	----------------------	---------------------------

7471VA	A4	Spider 1-Arm, lång   spider 1-arm, long
--------	----	---

\*Andra borrhål dimensioner är möjliga. Avlånga hål är också möjligt. Ange vid beställning. \*Other bore hole diameters possible on request. Oblong holes are also possible. Alla spiders kan beställas med hål/stift för att förhindra vridning vid montage. All spider arms are available with a turn-lock on request.



TRAV ja TRPV-testatut helat | TRAV and TRPV point fixing

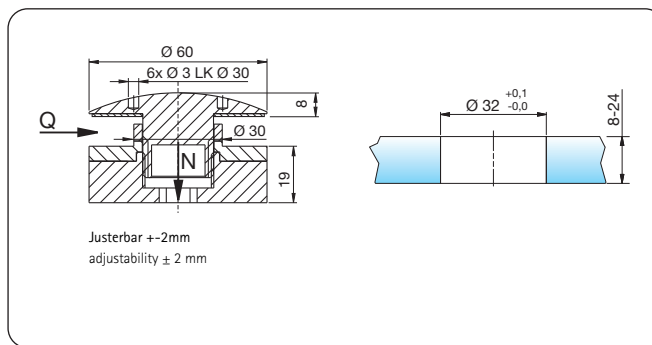

Art.nr article no.	Material material	Benämning article name		max. Q	max. N	Godkännande approval
7016VA	A2	Punktfäste (TRAV), utanpåliggande	8 - 12 mm	4,0 kN	6,0 kN	TRAV
7016VA-16		point fixing (TRAV), raised head	12 - 16 mm			
7016VA-20			16 - 20 mm			
7016VA-24			20 - 24 mm			

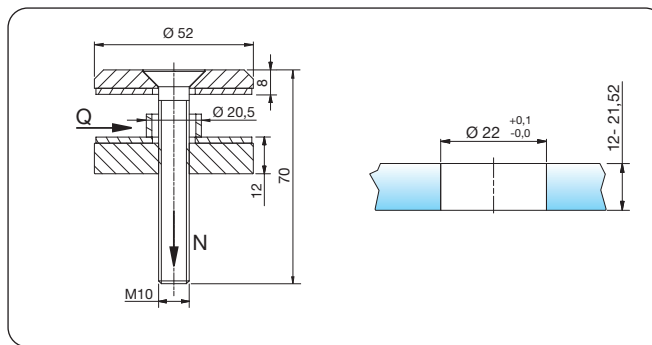

\*Helgängad skruv  
\*full-threaded screw

Art.nr article no.	Material material	Benämning article name		max. Q	max. N	Godkännande approval
7078VA	A2	Punktfäste (TRAV), utanpåliggande	12 - 21,52 mm	4,0 kN	6,0 kN	TRAV, TRPV
		point fixing (TRAV), raised head				



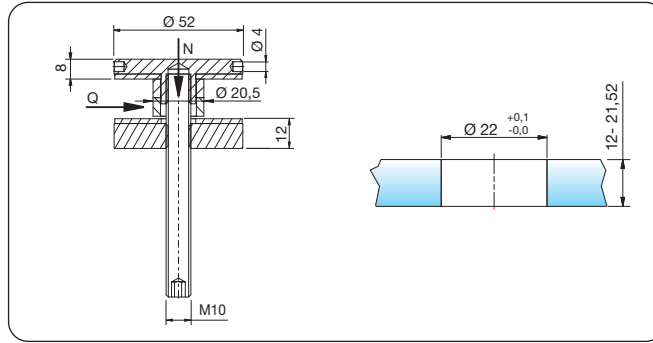

Tillbehör | accessories

- Z060
- S2342A2D10x100

inklusive | includes

- DIN913 M10 x 90 mm

Art.nr article no.	Material material	Benämning article name	Huvud head	max. Q	max. N	Godkännande approval
7072VA	A2	Punktfäste (TRAV), utanpåliggande 12 - 21,52 mm point fixing (TRAV), raised head	platt flat	4,0 kN	6,0 kN	TRAV, TRPV

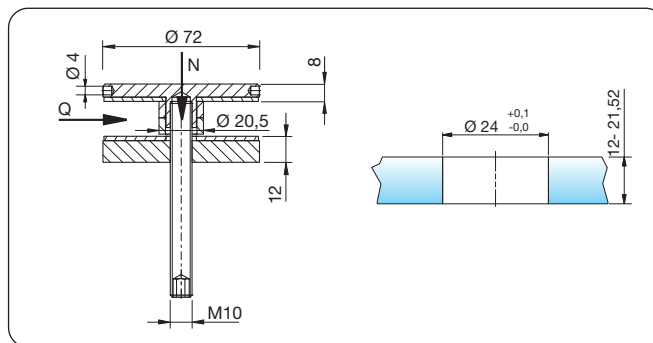

Tillbehör | accessories

- Z060
- S2342A2D10x100

inklusive | includes

- DIN913 M10 x 90 mm

Art.nr article no.	Material material	Benämning article name	Huvud head	max. Q	max. N	Godkännande approval
7073VA	A2	Punktfäste (TRAV), utanpåliggande 12 - 21,52 mm point fixing (TRAV), raised head	platt flat	4,0 kN	6,0 kN	TRAV, TRPV

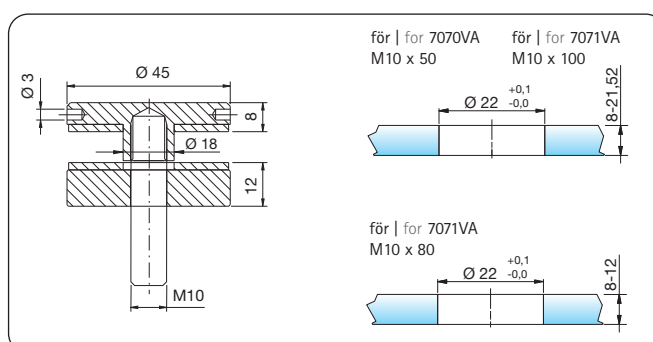

Tillbehör | accessories

- Z060
- 7071VA M10 x 80 mm

inklusive | includes

- 7070VA M10 x 50 mm
- 7071VA M10 x 100 mm

Art.nr article no.	Material material	Benämning article name	Huvud head
7070VA / 7071VA	A2	Punktfäste Ø 45, utanpåliggande point fixing Ø 45, raised head	platt flat



# TRAV ja TRPV-testatut helat | TRAV and TRPV point fixing

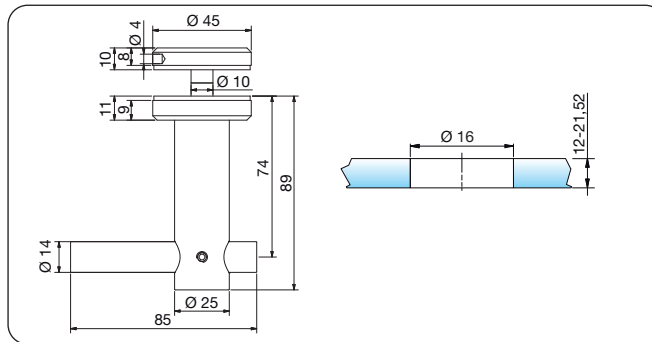

Tillbehör | accessories

Z060 S7991A2D6X12

Anslutningsplatta för handledare, (s. 96-97, Beslagskatalogen 2010/11)  
adapter plates for handrail, (p. 96/97, Handbook 2010/11)

Art.nr article no.	Material material	Benämning article name
10238044A2	A2	Handledshållare för glasmontage, med invändig gänga. handrail support with glass connector, with internal thread

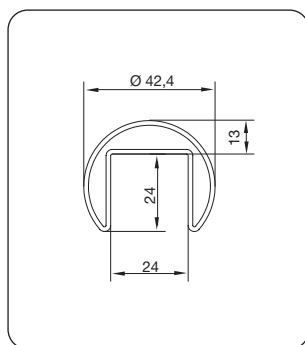

INFO

Tillbehör till våra handledare finner ni på sid 126 och framåt i Beslagskatalogen 2010/11

accessories for our slotted tube can be found on p. 126 ff., Handbook 2010/11

Art.nr article no.	Material material	Benämning article name	Ø	L
10213642A4	A4	Spårat handledarrör slotted round tube	42,4 x 1,5	6000

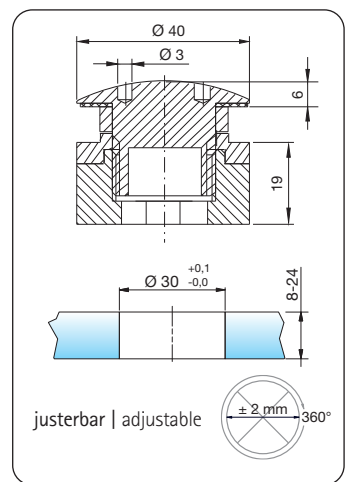
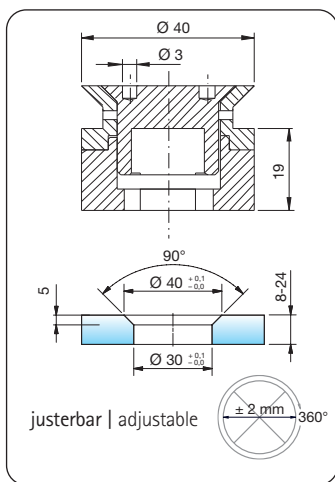

Art.nr article no.	Material material	Benämning article name	
7000VA / 7001VA	A2	Punktfäste Ø 40, försänkt	8 - 12 mm
7000VA-16 / 7001VA-16		point fixing Ø 40,	12 - 16 mm
7000VA-20 / 7001VA-20		flush	16 - 20 mm
7000VA-24 / 7001VA-24			20 - 24 mm

Art.nr article no.	Material material	Benämning article name	
7005VA	A2	Punktfäste Ø 40, utanpåliggande	8 - 12 mm
7005VA-16		point fixing Ø 40, raised head	12 - 16 mm
7005VA-20			16 - 20 mm
7005VA-24			20 - 24 mm



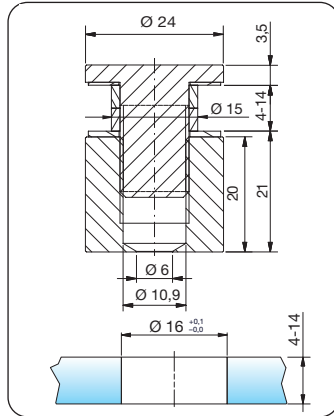

Art.nr article no.	Material material	Benämning article name
7063VA	A2	Punktfäste $\varnothing$ 24, utanpåliggande point fixing $\varnothing$ 24, raised head

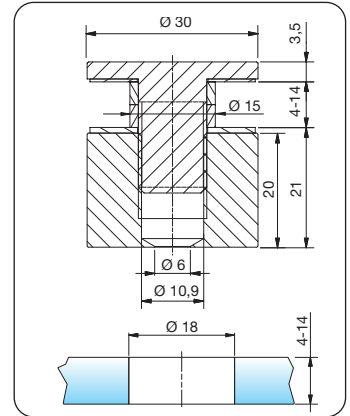

Art.nr article no.	Material material	Benämning article name
7064VA	A2	Punktfäste $\varnothing$ 30, utanpåliggande point fixing $\varnothing$ 30, raised head

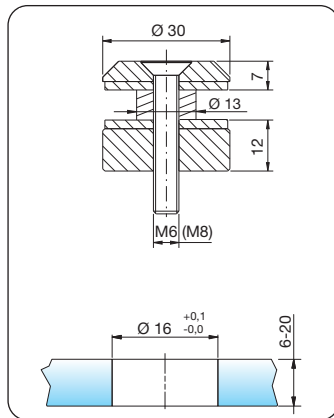

Art.nr article no.	Material material	Benämning article name
7082VA 7082VA-M8 7083VA	A2	Punktfäste $\varnothing$ 30, utanpåliggande 6 - 12 mm point fixing $\varnothing$ 30, raised head 6 - 20 mm 6 - 12 mm

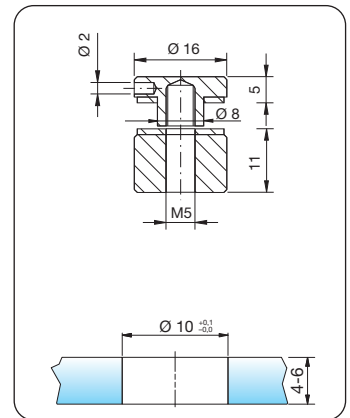

Art.nr article no.	Material material	Benämning article name
7074VA / 7075VA	A2	Punktfäste $\varnothing$ 16, utanpåliggande point fixing $\varnothing$ 16, raised head

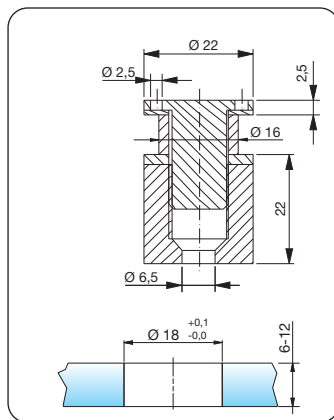

Art.nr article no.	Material material	Benämning article name
7061VA	A2	Punktfäste $\varnothing$ 22, utanpåliggande point fixing $\varnothing$ 22, raised head

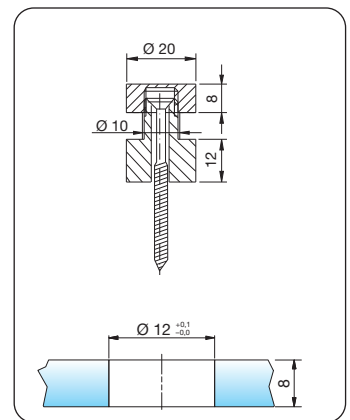

Art.nr article no.	Material material	Benämning article name
7120E0	Aluminium	Punktfäste $\varnothing$ 20, utanpåliggande point fixing $\varnothing$ 20, raised head





Tillbehör | accessories

Z057

inklusive | includes

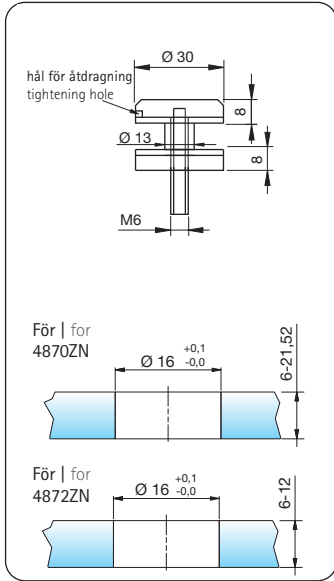
- 4870ZN  
M6 x 60 mm
- 4872ZN  
6 x 60 mm





Tillbehör | accessories

Z057

inklusive | includes

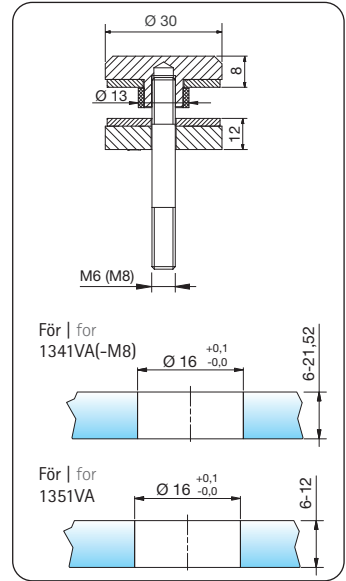
- 1341VA(-M8)  
M6(M8) x 60 mm
- 1351VA  
6 x 60 mm



Art.nr article no.	Gängstång thread	Material material	Benämning article name
4870ZN	M6 x 60 mm	Zink zinc	Punktfäste Ø 30, utanpåliggande point fixing Ø 30, raised head
4872ZN	6 x 60 mm	zinc	

Art.nr article no.	Gängstång thread	Material material	Benämning article name
1341VA	M6 x 60 mm	A2	Punktfäste Ø 30, utanpåliggande point fixing Ø 30, raised head
1341VA-M8	M8 x 60 mm		
1351VA	6 x 60 mm		

Färg | colour



Färg | colour

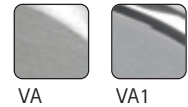

justerbar | adjustable

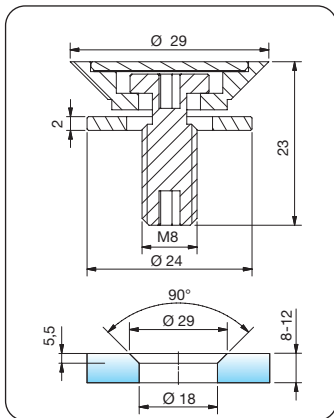
Art.nr article no.	Material material	Benämning article name
7654E0	Aluminium	Punktfäste Ø 29, försänkt point fixing Ø 29, flush



JOHN BERGER OÜ

FINLAND-ESTONIA-SWEDEN

Laki 9a, 10621 Tallinn, Eesti  
+358 40 9008520 / +372 654 6604  
info@johnberger.fi / info@johnberger.ee  
www.johnberger.fi